

# Prizmatix

## UHP-T-LA Ultra-High Power LED Light Source

Ver. 03

### Introduction

The UHP-T-LA LED series Ultra High Power LEDs (~50 Watt) utilize dense packaged LED Array to produce powerful collimated beam (direct illumination).

LED Array technology allows to create illumination at wavelengths where single large emitter (EP, DI and MP series) technology is not available.

LED Array technology is useful in many power demanding applications such as direct microplate illumination, fluorescence, microscopy and machine vision.

The UHP-T-LA optics contains primary CPC (Compound Parabolic Concentrator) style lens followed by collimating aspheric lens to optimize illumination and provide beam adjustment.

The LED current controller supports CW or pulsed operation via TTL trigger. The LED power can be controlled by 10 turn dial or via Analog input (0-5V).

The UHP-T-LA LEDs are available in violet, blue, yellow, red and near IR wavelengths.

The product can be used in various configurations such as collimated light source, directly connected to microscope, coupled to liquid light guide or coupled to optical fiber. Multi-wavelength light source can be easily created by several UHP-T units combined by a Beam Combiner.



### Key Features

- Ultra-High Power LED Array
- Optically isolated TTL input for external triggering (no shutter needed) or strobe operation
- Optically isolated Analog input (0-5V) for LED power control by external device like D/A interface
- Computer control via USB by Windows software, LabView VI or uManager (optional).
- Long life (no lamp or laser tube replacement required)
- Compatible with Prizmatix modular Microscope-LED Light Source products family – see below for details.
- Stable precisely adjustable power

---

#### Main Office

Phone: +972-72-2500097

Fax: +972-72-2500096

sales@prizmatix.com

#### European Sales Office

Phone: +44 (0)77-9172-9592

Fax: +44 (0)20-7681-2977

sales.europe@prizmatix.com

#### North America Sales Office

Phone: +1-(248)-436-8085

Fax: +1-(248)-281-5236

sales.usa@prizmatix.com

---

P.O.B. 244 Givat-Shmuel 54101, Israel

---

# Prizmatix

## Applications

- Fluorescence microscopy
- *In-Vitro* Optogenetics
- Microplate illumination, Petri Dish illumination
- Whole body imaging of small animals
- Bio analysis
- OEM

## Optical Specifications – Color LEDs

P/N	Peak [nm]	Centroid [nm]	FWHM [nm]	Power Collimated [mW]
UHP-T-505-LA	506	508	37	1000
UHP-T-470-LA	467	469	27	4700
UHP-T-595-LA	598	596	17	720
UHP-T-730-LA	734	730	35	800

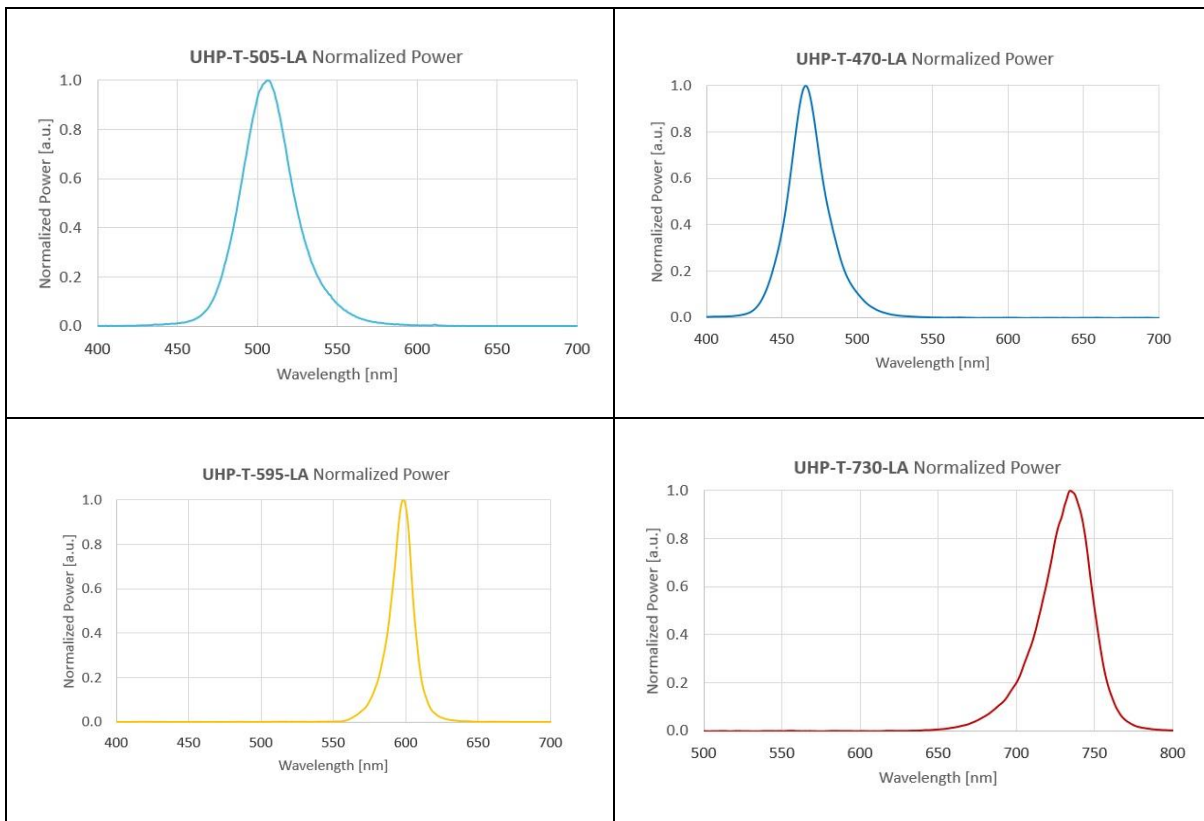

### Main Office

Phone: +972-72-2500097

Fax: +972-72-2500096

sales@prizmatix.com

### European Sales Office

Phone: +44 (0)77-9172-9592

Fax: +44 (0)20-7681-2977

sales.europe@prizmatix.com

### North America Sales Office

Phone: +1-(248)-436-8085

Fax: +1-(248)-281-5236

sales.usa@prizmatix.com

# Prizmatix

## Benchtop LED Current Controller Specifications

- Constant current or chopping modes
- Precise LED current setting by 10 turn dial
- TTL external trigger input
- Analog input for external LED power control (0-5Vdc)
- Optically isolated TTL and Analog inputs
- Compact and robust enclosure



Connectors for TTL and Analog input		Optically Isolated BNC
Digital modulation frequency	Hz	DC - 10000
Rise / Fall time	µs	<10 / <3
Analog input voltage range	V	0 - 5
Analog modulation frequency	Hz	DC - ~100
Current controller supply voltage	V	12
Power adaptor input		85-264 VAC, 47-63Hz, 1.5A

## General Specifications

Operation temperature range	°C	10 - 35
Storage temperature range	°C	-10 - 55
Operating relative humidity (Non condensing)	%	<90
Head dimensions		See drawing below
Head weight	g	350
Controller dimensions (L x W x H)	mm	197 x 174 x 80
Controller weight	g	400
Power adaptor dimensions (L x W x H)	mm	175 x 72 x 35
Power adaptor weight	g	650
Power Adaptor Safety		
LED Head fan noise	dBA	38

### Main Office

Phone: +972-72-2500097  
 Fax: +972-72-2500096  
 sales@prizmatix.com

### European Sales Office

Phone: +44 (0)77-9172-9592  
 Fax: +44 (0)20-7681-2977  
 sales.europe@prizmatix.com

### North America Sales Office

Phone: +1-(248)-436-8085  
 Fax: +1-(248)-281-5236  
 sales.usa@prizmatix.com

# Prizmatix

## Mechanical Drawings

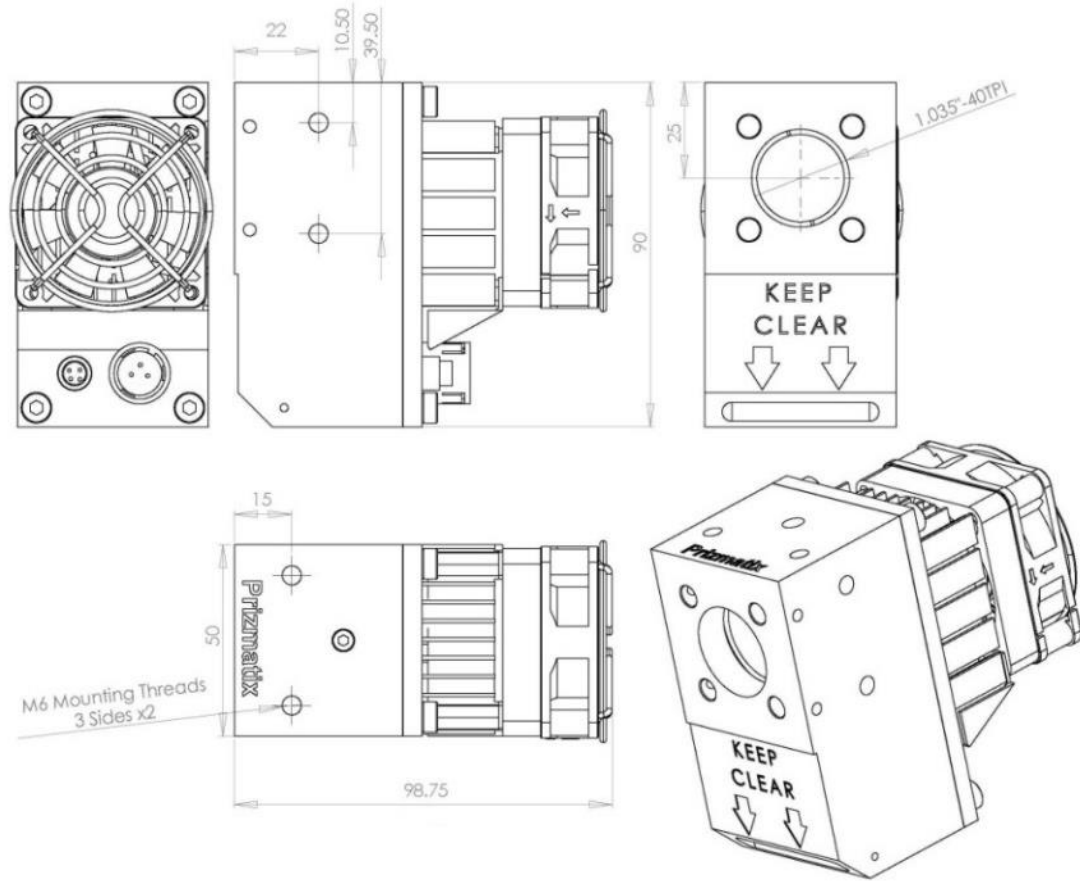

\* Specifications subject to changes without notice

---

### Main Office

Phone: +972-72-2500097  
Fax: +972-72-2500096  
sales@prizmatix.com

### European Sales Office

Phone: +44 (0)77-9172-9592  
Fax: +44 (0)20-7681-2977  
sales.europe@prizmatix.com

### North America Sales Office

Phone: +1-(248)-436-8085  
Fax: +1-(248)-281-5236  
sales.usa@prizmatix.com

---

P.O.B. 244 Givat-Shmuel 54101, Israel

---

# Prizmatix

## Optional Accessories

For full details on optional accessories please see:

<http://www.prizmatix.com/optogenetics/Optogenetics-LED-Light-Sources-and-Fiber-Optics.htm>

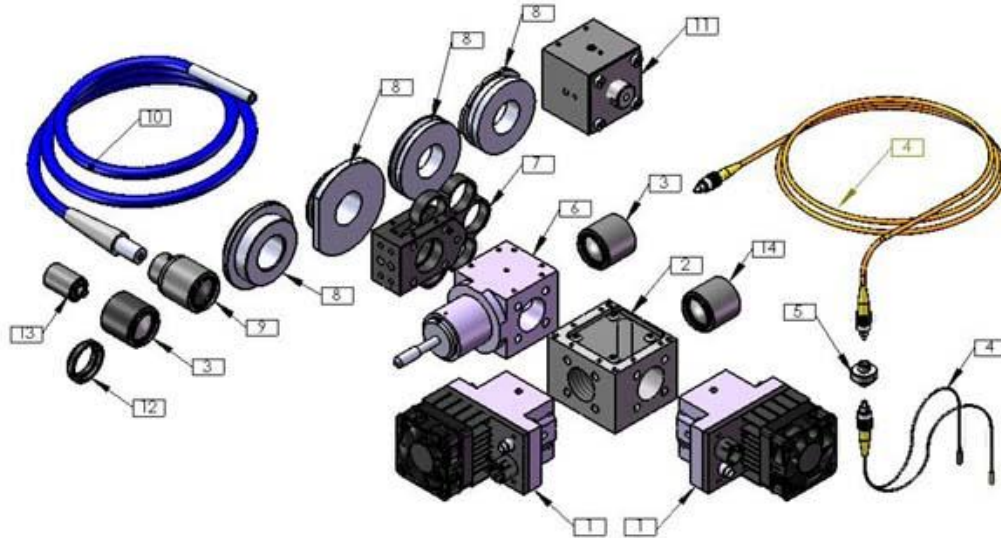

### Beam Combiner [2]:

Multiple LED beams can be combined into one output beam. For example UV LED can be combined with White LED to create Mercury lamp like configuration. For more details please see:

<http://www.youtube.com/watch?v=iv7dlwLHaUE>

### Filter Wheel [7]:

The UHP-Mic-LED can be equipped with a 6 positions filter wheel at the beam output. This accessory is especially useful for UHP-Mic-LED-White light source.

Please see <http://www.prizmatix.com/Optics/filter-wheel.htm> for more details.

### Fiber Coupler Adaptor [3]:

The UHP-Mic-LED can be easily changed from direct microscope coupling to fiber coupled LED configuration by means of Fiber Coupler Adaptor (SMA, CF or ST connector). Please see video clip

<http://www.youtube.com/watch?v=iv7dlwLHaUE> for more details.

### Liquid Light Guide Adaptor [9]:

The Microscope-LED can be easily changed from direct microscope coupling to Liquid Light Guide coupled LED configuration by means of LLGA Adaptor. Please see video clip

<http://www.youtube.com/watch?v=iv7dlwLHaUE> for more details.

### Fiber Optics Collimator [13]:

The output from optical fiber is divergent according to fiber NA. In order to reduce the divergence angle a collimator module can be used. Prizmatix collimator was especially designed to fit thick core high NA Polymer Optical Fibers. See more details at: <http://www.prizmatix.com/Optics/collimator.htm>

### Fiber Bundles [4]:

To combine outputs of multiple LEDs a Y-shaped fiber bundle with two or more input branches can be used. Prizmatix can help to configure and build custom fiber bundles for specific applications. See more details at: <http://www.prizmatix.com/dev/Custom-Fiber-Optic-Assemblies.htm>

---

#### Main Office

Phone: +972-72-2500097

Fax: +972-72-2500096

[sales@prizmatix.com](mailto:sales@prizmatix.com)

#### European Sales Office

Phone: +44 (0)77-9172-9592

Fax: +44 (0)20-7681-2977

[sales.europe@prizmatix.com](mailto:sales.europe@prizmatix.com)

#### North America Sales Office

Phone: +1-(248)-436-8085

Fax: +1-(248)-281-5236

[sales.usa@prizmatix.com](mailto:sales.usa@prizmatix.com)

---

P.O.B. 244 Givat-Shmuel 54101, Israel

---