

Prizmatix

Implantable Fiber Optic Cannula for Optogenetics

Fiberoptic Accessory for *in-vivo* Optogenetics Applications

Ver. 13

Introduction

Prizmatix implantable fiberoptic cannula for Optogenetics experiments allows direct light stimulation of certain deep brain regions in living animals.

Each Cannula consists of a Zirconia ferrule accommodating a high NA optical fiber, protruding from Zirconia ferrule at desired length. The fiber is machine-cut according to customer request to accommodate specific lengths, the ferrule is then optically polished to ensure high quality optical coupling and reliability.

All cannula components are biocompatible, implantable and non-metallic, making them NMR/MRI compatible.

Standard and custom built cannulae are also available in two ferrules diameters: 2.5mm and lightweight 1.25mm for smaller animals as mice.

Zirconia Mating Sleeves for these cannulae are available from Prizmatix.

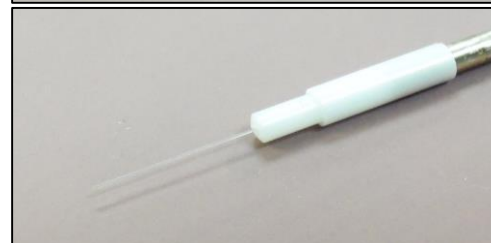
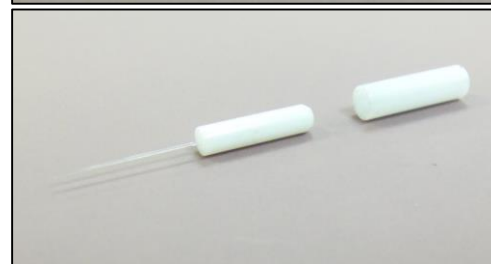

Key Features

- Zirconia ferrules – 2.5mm or lightweight 1.25mm outer diameter e.g. for mice.
- High NA fibers – 200 μ m (NA 0.66), 250 μ m (NA 0.66), 400 μ m (NA 0.53), 500 μ m core (NA 0.63)
- Machine cut to customer-specified length
- Biocompatible and Implantable
- Adheres to the cement fixing the cannula to the skull.
- NMR/MRI compatible, no metallic components
- Optical quality processed ends
- Sterilizable – alcohol, ETO, autoclave (65°C/1 hour cure)
- Electrically isolating

Applications

- * *In-vivo* Optogenetics in behaving animals

Main Office

Phone: +972-72-2500097
Fax: +972-72-2500096
sales@prizmatix.com

European Sales Office

Phone: +44-(0)77-9172-9592
Fax: +44-(0)20-7681-2977
sales.europe@prizmatix.com

North America Sales Office

Phone: +1-(248)-436-8085
Fax: +1-(248)-281-5236
sales.usa@prizmatix.com

P.O.B. 244 Givat-Shmuel 5410102, Israel

Prizmatix

Specifications

Fiber length protruding from cannula:

Fiber Core Diameter	Fiber Outer Diameter	NA	L*, (mm)
New!! 500 μm	510 μm	0.63	$0.5 < L < 50$
400 μm	470 μm	0.53	$0.5 < L < 50$
New!! 250 μm	275 μm	0.66	$0.5 < L < 50$
200 μm	225 μm	0.66	$0.5 < L < 50$

* Same price for any standard or custom length.

Long scissors-cut cannulae for DIY cleaving are available at reduced price.

Examples of pulsed output from Prizmatix Optogenetics-LED-Blue after rotary joint:

Fiber Core Diameter	Fiber Outer Diameter	NA	Power	Irradiance
New!! 500 μm	510 μm	0.63	>60mW	>320mW/mm ²
400 μm	470 μm	0.53	>40mW	>320mW/mm ²
New!! 250 μm	275 μm	0.66	>15mW	>320mW/mm ²
200 μm	225 μm	0.66	>10mW	>320mW/mm ²

Examples of output from Optogenetics-LED-Green / Red / Deep-Red after rotary joint:

Fiber Core Diameter	Fiber Outer Diameter	NA	Power	Irradiance
New!! 500 μm	510 μm	0.63	>24mW	>130mW/mm ²
400 μm	470 μm	0.53	>16mW	>130mW/mm ²
New!! 250 μm	275 μm	0.66	>6mW	>130mW/mm ²
200 μm	225 μm	0.66	>4mW	>130mW/mm ²

Zirconia Ferrule specifications:

		Diameter	
		2.5mm	1.25mm
Zirconia ferrule length	mm	10.5	6.45
Sleeve Pull Force	N	1.5 - 4.5	1.0 - 2.9
Cannula Typical Weight	grams	< 0.5	< 0.1

Mechanical Drawings

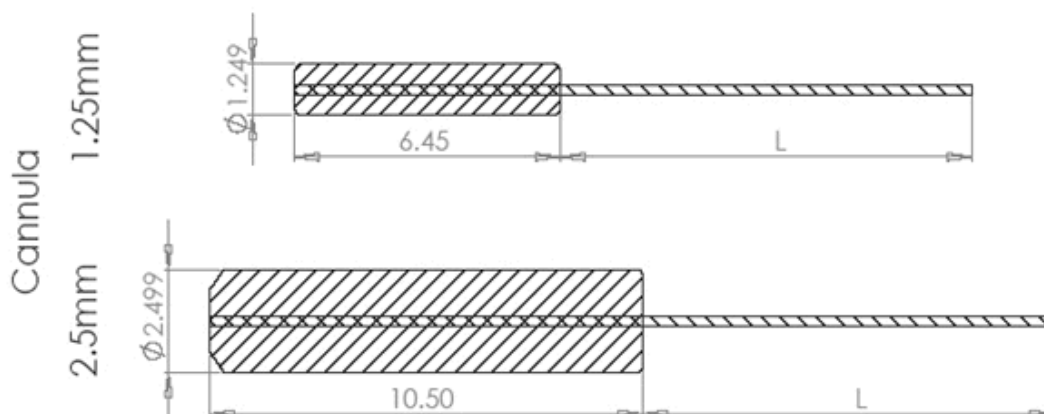

- L- Fiber Length protruding from cannula. See specification table for details.
- Zirconia Mating Sleeves for these cannulae are available from Prizmatix.

Main Office

Phone: +972-72-2500097

Fax: +972-72-2500096

sales@prizmatix.com

European Sales Office

Phone: +44-(0)77-9172-9592

Fax: +44-(0)20-7681-2977

sales.europe@prizmatix.com

North America Sales Office

Phone: +1-(248)-436-8085

Fax: +1-(248)-281-5236

sales.usa@prizmatix.com

Prizmatix

Additional Information

Prizmatix Cannulae are specially designed for working with high NA fibers and LED light sources. Unlike Lasers, Prizmatix Ultra High Power LEDs have a high-Brightness large emitting area and wide angle radiance.

We use this characteristic to couple the LEDs light efficiently into a high numerical aperture ($NA \geq 0.5$) primary large core fiber, e.g. 1000um core. Due to the large core of the primary fiber, coupling a secondary fiber ($NA \geq 0.5$) with smaller core, e.g. 500um, does not require precise axial alignment. Having the fibers close enough to each other, just keeping the small core in front of the larger core – it keeps efficient light coupling.

With Prizmatix Rotary Joint for *in-vivo* experiments, the primary fiber is connected to the top port of the fiberoptic rotary joint and the secondary fiber is connected to the bottom of the rotary joint. Prizmatix rotary joint consists of a special low-friction ball bearing enables the two fibers to rotate freely upon each other.

The brightness, usually measured in mW/mm^2 , is basically conserved along the fiberoptic chain from the LED light source towards the rotary joint and the implanted cannula, provided the Numerical Aperture (NA) is preserved and despite the fact that core diameter of the fiber optic components in the system get smaller.

The large core to small core(s) coupling method, allows the secondary fiber to have more than one branch, still using a single LED light source and without compromising the brightness. This is very useful for comprehensive research, such as optogenetically manipulation of two brain hemispheres or at several locations simultaneously – see figure next page.

Prizmatix Rotary Joint is suitable for systems based on LEDs and high NA fibers as Prizmatix offer in the Optogenetics Toolbox:

<http://www.prizmatix-led.com/Optogenetics-LED-Light-Sources-and-Fiber-Optics.htm>

The high-NA Cannulae are the last component in this fiberoptic chain, exploiting the most of Prizmatix Optogenetics LEDs.

Main Office

Phone: +972-72-2500097

Fax: +972-72-2500096

sales@prizmatix.com

European Sales Office

Phone: +44-(0)77-9172-9592

Fax: +44-(0)20-7681-2977

sales.europe@prizmatix.com

North America Sales Office

Phone: +1-(248)-436-8085

Fax: +1-(248)-281-5236

sales.usa@prizmatix.com

P.O.B. 244 Givat-Shmuel 5410102, Israel

Prizmatix

Optional Accessories

Prizmatix offers a full range of modules for in-vivo optogenetics starting from the single wavelength plug-and-go Optogenetics-LED to multi-wavelength systems for activation and silencing, with speeds of better than millisecond-scale temporal precision.

In-Vivo Optogenetics Toolbox for Freely Moving Mammals

The In-Vivo Optogenetics Toolbox includes all optical components required for Optogenetics experiments in freely moving animals

- [1] Optogenetics-LED
- [2] Fiber Patch Cord
- [3] Rotary Joint
- [4] Cannulae
- [5] Pulsar

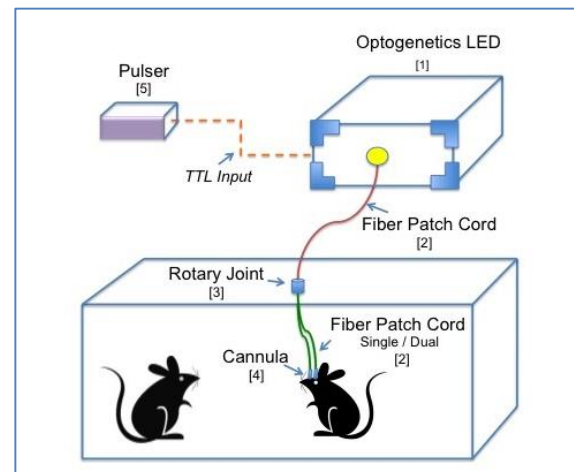

For more information please see:

www.prizmatix.com/Optogenetics/Prizmatix-in-vivo-Optogenetics-Toolbox.htm

In-Vitro/ In Situ Optogenetics Toolbox

The In-Vitro/ In Situ Optogenetics Toolbox include numerous optical components required for Optogenetics experiments under microscope or other setups like 96 well plate.

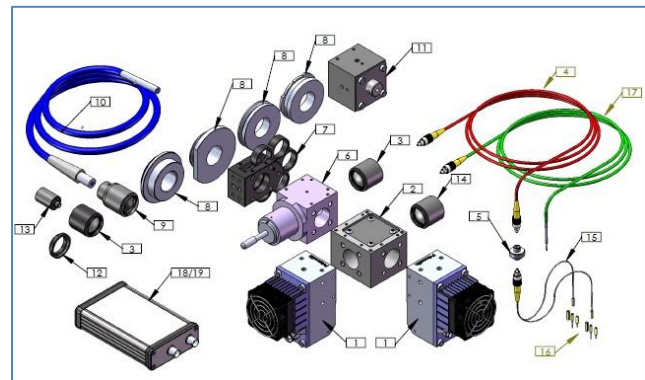

Main components of the toolkit are:

- [1] Ultra High Power LED
- [2] Beam Combiner
- [3] Fiber Coupler Adaptor

For more information please see:

<http://www.prizmatix.com/optogenetics/Optogenetics-LED-Light-Sources-and-Fiber-Optics.htm>

Main Office

Phone: +972-72-2500097
Fax: +972-72-2500096
sales@prizmatix.com

European Sales Office

Phone: +44-(0)77-9172-9592
Fax: +44-(0)20-7681-2977
sales.europe@prizmatix.com

North America Sales Office

Phone: +1-(248)-436-8085
Fax: +1-(248)-281-5236
sales.usa@prizmatix.com