

# Prizmatix

---

## Cure-LED User Manual



March 2012

---

**Main Office**

Phone: +972-72-2500097  
Fax: +972-72-2500096  
sales@prizmatix.com

**European Sales Office**

Phone: +44 (0)77-9172-9592  
Fax: +44 (0)20-7681-2977  
sales.europe@prizmatix.com

**North America Sales Office**

Phone: +1-(248)-436-8085  
Fax: +1-(248)-281-5236  
sales.usa@prizmatix.com

---

P.O.B. 4234 Modiin-Ilite 71919, Israel

---

# Prizmatix

---

## **UV Curing System Description**

The UV Curing System is a High Power LED light source for UV adhesive and ink curing and other UV applications. The LED controller supports external foot pedal control and optional computer control of power and illumination duration.

## **Safety**

Before applying power to the power adaptor of the system ensure that the protective conductor of the three-conductor mains power cord is correctly connected to the protective earth contact of the socket outlet! Improper grounding can cause electric shock and damage to health or even death!

When wiring the device first disconnect it from the power source and then turn OFF the main switch on the front panel. Failure to do so may result in electric shock, injury and/or damage of your equipment.

Prizmatix products are NOT authorized for use as components in life support devices or systems.

The LED Current Controller and Cure-LED heads must not be operated in explosion endangered environments!

Any maintenance shall be performed ONLY by a Prizmatix authorized technician.

The head of the Cure-LED can emit UV and other intense light!

When using a UV LED intense ultraviolet light can be emitted by the system during operation. Precautions must be taken to prevent looking directly at the UV light with unprotected eyes or the shining of UV light onto bare skin. Do not look directly into the UV light or through the optical system during operation of the device: this can be harmful to the eyes even for short periods due to the high intensity of the UV light.

If it is necessary to view the LED's beam use protective glasses to avoid damage by the intense light.

**ATTENTION: USE SAFETY GLASSES WHEN WORKING WITH UV CURING SYSTEM**

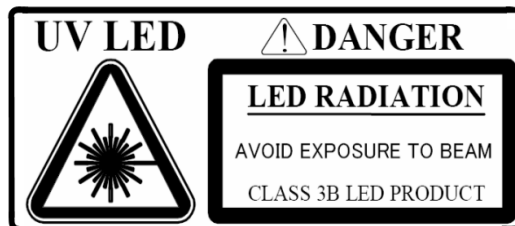

---

### **Main Office**

Phone: +972-72-2500097  
Fax: +972-72-2500096  
sales@prizmatix.com

### **European Sales Office**

Phone: +44 (0)77-9172-9592  
Fax: +44 (0)20-7681-2977  
sales.europe@prizmatix.com

### **North America Sales Office**

Phone: +1-(248)-436-8085  
Fax: +1-(248)-281-5236  
sales.usa@prizmatix.com

---

P.O.B. 4234 Modiin-Ilite 71919, Israel





---

# Prizmatix

## **Unpacking and Set-up of the Device**

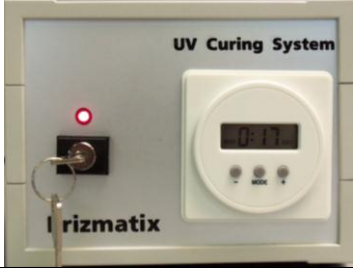
Remove the device from packaging and inspect it for loose components or any signs of damage. Notify Prizmatix if the device appears damaged in any way: do not install a damaged device.

### **Contents List:**

|   |   |
|---|---|
| Cure-LED Torch  | Cure-LED Controller with two Keys   |
|    |     |
| Pedal   | LED Current Cable   |
|   |   |
| Mains Power Cord  | Power Adaptor   |
|  |  |

| # | Item                | Description  | QTY |
|---|---------------------|--|-----|
| 1 | Cure-LED Head       | LED Torch with heat sink                           | 1   |
| 2 | Cure-LED Controller | Cure-LED Bench top Current Controller with timer   | 1   |
| 3 | Switch Keys         | Switch keys for ON/OFF power switch                | 2   |
| 4 | Pedal               | Foot Pedal for arms free control of the Cure-LED   | 1   |
| 5 | Mains Power Cord    | Cord to connect the power adaptor to mains voltage | 1   |
| 6 | Power Adaptor       | Universal power adaptor                            | 1   |

#### **Main Office**

Phone: +972-72-2500097  
 Fax: +972-72-2500096  
[sales@prizmatix.com](mailto:sales@prizmatix.com)

#### **European Sales Office**

Phone: +44 (0)77-9172-9592  
 Fax: +44 (0)20-7681-2977  
[sales.europe@prizmatix.com](mailto:sales.europe@prizmatix.com)

#### **North America Sales Office**

Phone: +1-(248)-436-8085  
 Fax: +1-(248)-281-5236  
[sales.usa@prizmatix.com](mailto:sales.usa@prizmatix.com)

P.O.B. 4234 Modiin-Ilite 71919, Israel

# Prizmatix

---

## System overview:

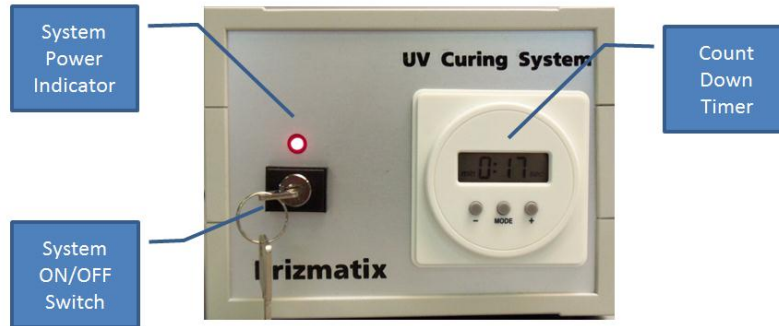

Figure 1: Front panel of Cure-LED Current Controller

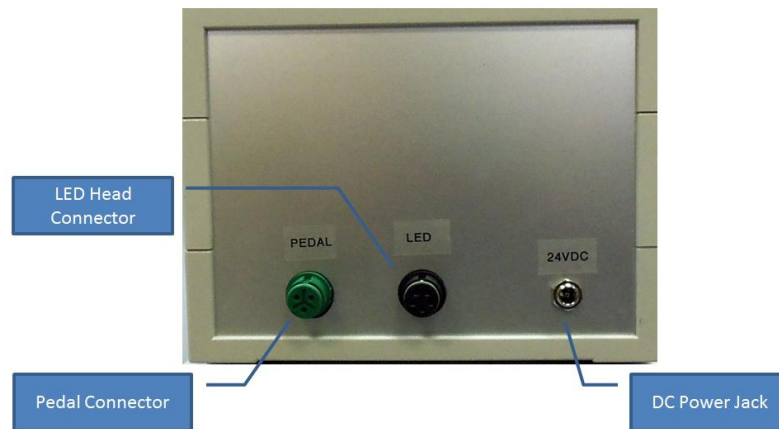

Figure 2: Rear panel of Cure-LED Current Controller

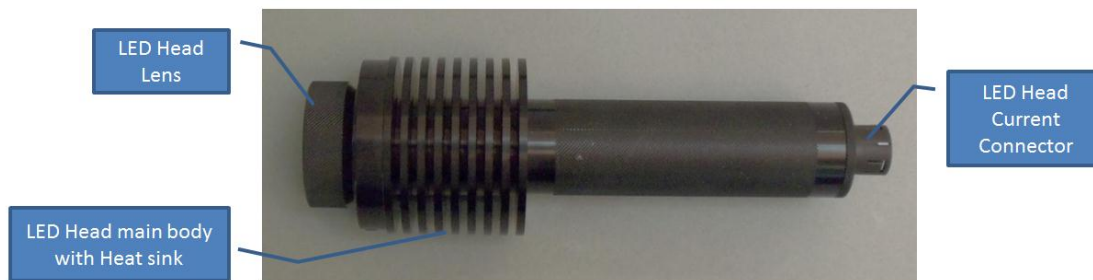

Figure 3: Cure-LED Torch

---

### Main Office

Phone: +972-72-2500097  
Fax: +972-72-2500096  
sales@prizmatix.com

### European Sales Office

Phone: +44 (0)77-9172-9592  
Fax: +44 (0)20-7681-2977  
sales.europe@prizmatix.com

### North America Sales Office

Phone: +1-(248)-436-8085  
Fax: +1-(248)-281-5236  
sales.usa@prizmatix.com

---

P.O.B. 4234 Modiin-Ilite 71919, Israel

---

# Prizmatix

---

## Setting up the Cure-LED System

1. The general cabling system is shown in the diagram below:

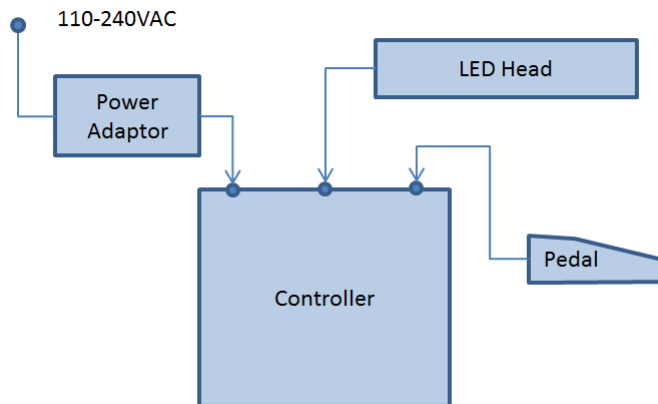

Figure 4: Cure-LED cable connection

2. Put the Key in the Power Switch of the Cure-LED Current Controller and ensure it is turned to the OFF position.
3. Connect the LED Current Cable to the Cure-LED Current Controller and to the LED Head.
4. Connect the Foot Pedal Cable to the Current Controller.
5. Connect the Power Adaptor cord to the DC jack on the back panel of the Current Controller.
6. Connect the Mains Power Cord to the Power Adaptor.
7. Plug the Power Adaptor into the wall outlet with the Mains Power Cord.
8. Turn the Key Switch to ON position. The small red indicator on the front panel will light ON and 0:00 will be displayed on the Timer display.

---

**Main Office**

Phone: +972-72-2500097  
Fax: +972-72-2500096  
sales@prizmatix.com

**European Sales Office**

Phone: +44 (0)77-9172-9592  
Fax: +44 (0)20-7681-2977  
sales.europe@prizmatix.com

**North America Sales Office**

Phone: +1-(248)-436-8085  
Fax: +1-(248)-281-5236  
sales.usa@prizmatix.com

---

P.O.B. 4234 Modiin-Ilite 71919, Israel

---

# Prizmatix

---

## **Operation of the Cure-LED System:**

1. Wear safety glasses each time you use the system!
2. Turn the Key Switch to ON position. The small red indicator on the front panel will light ON and 0:00 will be displayed on the Timer display.
3. Use (+) and (-) knobs of the timer to set the required curing time.



Figure 5: LED Controller Timer

4. Press once the Mode knob to operate the Light for the set time period.
5. After the timer will finish the Count down the Light will be turned OFF and the bip sound will be sound.
6. If you need to use the Light for same period as last operation press again the Mode knob.
7. If different time is required – set the time by the (-) / (+) knobs.
8. In order to operate the UV Light by Pedal Press Pedal twice instead of pressing the Mode knob.
9. In any case or emergency use the key switch to shoot down the system power immediately.

---

### **Main Office**

Phone: +972-72-2500097  
Fax: +972-72-2500096  
sales@prizmatix.com

### **European Sales Office**

Phone: +44 (0)77-9172-9592  
Fax: +44 (0)20-7681-2977  
sales.europe@prizmatix.com

### **North America Sales Office**

Phone: +1-(248)-436-8085  
Fax: +1-(248)-281-5236  
sales.usa@prizmatix.com

---

P.O.B. 4234 Modiin-Ilite 71919, Israel

---